

Lithium battery Chargers

700W / 1500W

For Lithium Ion / Lithium Poymer battery only

For AC 220V only

Bidirectional control of external communication for automation system (option)

CE (for several models)



1500W charger

700W charger

Basic standard offering



AC power cord



Output line

Option offering



Anderson connector line

Table of Contents

0. Important Notices.....	3
How to Select Charging Voltage	3
Cautions when using Chargers.....	3
Cautions on the Type and Capacity of Lithium Ion battery	5
Cautions on the Capacity of the Lithium Battery to be applied.	5
1. Specifications – 700W Series	6
2. Specifications – 1500W Series	8
3. Common Specifications for all models.....	10
Charge current Adjustment Function	10
Bidirectional Communicating Function (COM) – Option	10
Charger and Lithium Battery Charging Characteristics	10
Characteristics of electric circuit.....	11
Procedures of Charge	11
Other Specification for Safety and Convenience.....	12
4. Model Number / Order Code / Option Marking	12
5. Selecting Connector Options.....	13
6. Product Drawings	14

0. Important Notices

How to Select Charging Voltage

Type	Charger Max. charging voltage	Approximate amount of charging	Considerations when selecting charging voltage
25V Battery (7S, 7 series)	28V	80%	Applied when the electric equipment installed in the load generates an error due to overvoltage at 29V *In case of AGV, this voltage range is selected generally.
	29V	90%	To maximize battery utilization. This could be applied if no problem occurs.
50V Battery (14S, 14series)	56V	80%	Applied when the electric equipment installed in the load generates an error due to overvoltage at 29V *In case of AGV, this voltage range is selected generally.
	58V	90%	To maximize battery utilization. This could be applied if no problem occurs.

Cautions when using Chargers

IMPORTANT CAUTIONS

-  When applying to an automatic charging station of an AGV (Automatic Guide Vehicle), Do not turn ON / OFF the AC input power to turn ON / OFF chargers. Because the Firmware (S / W) of the charger may malfunction in some cases.
It will operate automatically if the AC input power is always set to ON.

This charger detects the battery and charges it automatically only when the battery is connected. In other words, when the battery is not connected, there would be no outputs.

-  **Do not turn ON / OFF the AC input power to turn ON / OFF chargers.**
When applying to an automatic charging station of an AGV (Automatic Guide Vehicle), Do not turn ON / OFF the AC input power to turn ON / OFF chargers. Because the Firmware (S / W) of the charger may malfunction in some cases. It will operate automatically if the AC input power is always set to ON.

-  **When the battery is not connected, there would be no outputs.**

This charger detects the battery and charges it automatically only when the battery is connected.

⚠ When cannot boot powered on AC (No durability issues)

When power is applied, it is recommended to observe the following procedure.

- 1) When 220V AC power is applied, the switch must be OFF.
- 2) Turn on the switch after turning on the power.

* If there is no response from the above,

- 3) After the power switch is off and 220V AC is shorted, wait until the internal capacitor is fully discharged. (maximum 1 minute)
 - 4) After waiting, try again in the above order,
- If there is no response afterwards, please fill out the application form and send it to us.

⚠ Make sure the applied battery is suitable for the charger.

Do not connect lead acid storage batteries. The charging voltage specification may not be suitable for the charger. The charger can be used only when the charging voltage of it is lower than the maximum voltage of the battery. Connect +, - on the output terminal block to the battery terminal.

⚠ The use of thin wires compared to the current causes a fire accident due to deterioration of the wires and connectors in the long term..

The wire thickness is not determined by the capacity and size of the battery, but is determined by the size of the used current (charge current and discharge current).

◇ In a room temperature environment, the allowable current per 1 mm² (square millimeter) of wire is about 5A.

The allowable current = 5A / mm² (SQMM).

In a high temperature environment, use wires that are thicker than the formula above.

[Selection example]

(Example 1)

If the maximum charge current is designed as 25A, the charge wire thickness is: $25A / (5A / \text{mm}^2) = 5 \text{ mm}^2$ or more.

(Example 2)

If the maximum charge current is designed as 45A, the charge wire thickness is: $45A / (5A / \text{mm}^2) = 9 \text{ mm}^2$ or more.

⚠ The ability of the charger to recharge when the battery voltage drops after the battery is fully charged .

With the charger and battery connected at all times

The battery can be used in conjunction with a load device.

At this time, the charger resumes charging operation when the battery falls below a certain voltage. This voltage is called the recharge start voltage.

- * Model : TC-700W-25V□□A → The recharge start voltage = Around 25.9V
- * Model : TC-1500W-25V□□A → The recharge start voltage = Around 25.9V
- * Model : TC-700W-50V□□A → The recharge start voltage = Around 51.8V
- * Model : TC-1500W-50V□□A → The recharge start voltage = Around 51.8V

 **Depending on the operating state of the charger, the LED signal will light up as shown below.**

- ◇ Green(●) : Charging completed
- ◇ Red(●) : Normal charging state
- ◇ Orange(●) : battery warning
- ◇ Orange flickering (●●●●···): battery changes polarity
- ◇ Red, Green flickering alternately (●●●●···): Flashes 3 to 4 times per second.
Normal operation for fine charging after under voltage state.
After several minutes, it turns red and charges normally.
- ◇ Green flickering(●●●●···): Standby state when battery is not connected / or Fine charging state.
- ◇ If there is a lot of heat in the connected lithium battery, stop charging. check again and recharge.

Cautions on the Type and Capacity of Lithium Ion battery

 **Cautions on the Maximum Voltage of Lithium Battery.**

The maximum voltage for lithium batteries in 7 series, varies depending on the manufacturer and may be 29.4 V or 30.1 V or more. 'TC-1500W-25V45A / Max29V' charger charges up to 29V. So if the maximum voltage of the battery is 30.1V or higher, it will charge about 5% less. But there is no problem to use.

Caution : Do not connect this charger with the maximum voltage of the lithium battery itself less than 29.4V.

Cautions on the Capacity of the Lithium Battery to be applied.

 **Maximum charge current when considering only lithium battery cell**

It is recommended to charge with maximum current to 0.5C or less. If the capacity of the lithium battery is 20Ah, 0.5C charging means charging with current less than 10A (= 20Ah x 50%) which is less than 50% of the battery capacity. Typical lithium ion battery cells can be charged up to 1 C, but this is the maximum value. We recommend 0.5 C or less for safety and long life.

However, this also depends on the lithium ion battery pack product, and the maximum charge current specifications are listed on each battery pack. Exceeding this value may cause the battery to malfunction, deteriorate its life, or sometimes overheat and damage it. Please refer to lithium battery manufacturer's charge current specification. Some lithium batteries may be available for charging up to 1C.

 **Maximum charge current considering capacity of BMS**

You must charge below the maximum charge current value set by BMS.

Some companies' lithium batteries can accumulate heat in the BMS when charged with the maximum charge current specified in the specification, which can cause the battery to overheat or accidents.

If it is not urgent, it is recommended to charge the battery slowly by reducing the charge current.

Our chargers are designed to reduce the charge current by considering the above problems.

1. Specifications – 700W Series

	Model name	Standard model	TC-700W-25V25A /Max29V	TC-700W-25V25A /Max28V	TC-700W-50V13A /Max58V	TC-700W-50V13A /Max56V
		Communication port (RS232C)	TC-700W-25V25A /Max29V/COM	TC-700W-25V25A /Max28V/COM	TC-700W-50V13A /Max58V/COM	TC-700W-50V13A /Max56V/COM
0	Certification					
1	Batteries	At room temperature	At least 5 mm ²		At least 3 mm ²	
2	Batteries	Li-Ion/Polymer	7 Series(7S), 25.2V or more, 29.4V charging max.		14 Series(14S), 50.4V or more, 58.8V charging max.	
3	Charging Voltage	Battery Max.Voltage when fully charged	29.0 VDC	28.0 VDC	58.0 VDC	56.0 VDC
4	Application	Considering acceptable Max.Voltage by the load	Standard	Recommended for Factory Automation, AGV Battery Systems	Standard	Recommended for Factory Automation, AGV Battery Systems
5	Charging Capacity	Full Charged Capacity	About 90%	About 80%	About 90%	About 80%
6	Charge current		Max. 27A±0.5A, (current ripples : under 3%) 4-steps current adjustment(13, 17 , 21, 27A)		Max. 13A±0.3A, (current ripples : under 3%) 4-steps current adjustment (6, 8, 10, 13A)	
7	Finishing Current		Approximately 10 – 20% of the normal charge current max. (Current that stops charging)			
8	How to Charge		CC/CV (Constant Current/ Constant Voltage), 4-steps current increase after charging starts (Slow Start)			
9	Type of Charger	Insulated	Primary/Secondary Insulated chargers (Safety management and noise reduction in case of ground fault)			
10	Input Voltage	RMS	180VAC ~ 240VAC / 50~60 Hz			
11	Input Power	RMS	About 887 VA	About 918 VA	About 816 VA	About 743 VA

	Model name	Standard model	TC-700W-25V25A /Max29V	TC-700W-25V25A /Max28V	TC-700W-50V13A /Max58V	TC-700W-50V13A /Max56V
		Communication port (RS232C)	TC-700W-25V25A /Max29V/COM	TC-700W-25V25A /Max28V/COM	TC-700W-50V13A /Max58V/COM	TC-700W-50V13A /Max56V/COM
12	Recommended Circuit Breaker(CB)	10A Circuit Breaker(CB) , considering surge current peak max. at initial start of chargers				
13	Standby Power	RMS	17W	←	←	←
14	Charging Power	RMS	756W max.	783W max.	728W max.	754W max.
15	Efficiency/PF		Efficiency 87% , Power Factor 98%		Efficiency 91% , Power Factor 98%	
16	Protection Features	Short circuit protection / over current protection / over voltage protection / reverse connection prevention / pre-charging / *BMS/PCM unblocking feature * BMS/PCM : Battery Management System / Protection Circuit Module				
17	Temperature	Operation : -20°C ~ +40°C / Storage : -20°C ~ +65°C				
18	Size / Weight	W 140mm x H 77mm x L 340mm , 3.5Kg				

* Please refer to the separate manual on the website for the communication protocol related to the communication port mounting type.

2. Specifications – 1500W Series

	Model name	Standard model	TC-1500W-25V45A /Max29V	TC-1500W-25V45A /Max28V	TC-1500W-50V25A /Max58V	TC-1500W-50V25A /Max56V
		Communication port (RS232C)	TC-1500W-25V45A /Max29V/COM	TC-150W-25V45A /Max28V/COM	TC-1500W-50V25A /Max58V/COM	TC-1500W-50V25A /Max56V/COM
0	Certification	CE	CE			
1	Output Wire Size	At room temperature	At least 10 mm ²		At least 5 mm ²	
2	Batteries	Li-Ion/Polymer	7series(7S), 25.2V or more, 29.4V charging max.		14series(14S), 50.4V or more, 58.8V charging max.	
3	Charging Voltage	Battery Max.Voltage when fully charged	29.0 VDC	28.0 VDC	29.0 VDC	28.0 VDC
4	Application	Considering acceptable Max.Voltage by the load	Standard	Recommended for automation power supply	Standard	Recommended for automation power supply
5	Charging Capacity	Full Charged Capacity	About 90%	About 80%	About 90%	About 80%
6	Charge current		Max. 45A±0.5A , (current ripples : under 3%) 4-steps current adjustment (18, 25 , 33, 45A)		Max. 25A±0.5A, (current ripples : under 3%) 4-steps current adjustment (13, 17 , 21, 25A)	
7	Finishing Current		Approximately 10 – 20% of the normal charge current max. (Current that stops charging)			
8	How to Charge		CC/CV (Constant Current/ Constant Voltage), 4-steps current increase after charging starts (Slow Start)			
9	Type of Charger	Insulated	Primary/Secondary Insulated chargers (Safety management and noise reduction in case of ground fault)			
10	Input Voltage	RMS	180VAC ~ 240VAC / 50~60 Hz			

	Model name	Standard model	TC-1500W-25V45A /Max29V	TC-1500W-25V45A /Max28V	TC-1500W-50V25A /Max58V	TC-1500W-50V25A /Max56V
		Communication port (RS232C)	TC-1500W-25V45A /Max29V/COM	TC-150W-25V45A /Max28V/COM	TC-1500W-50V25A /Max58V/COM	TC-1500W-50V25A /Max56V/COM
11	Input Power	RMS	About 1,332 VA	About 1,286 VA	About 1,332 VA	About 1,286 VA
12	Recommended Circuit Breaker(CB)		10A Circuit Breaker(CB) , considering surge current peak max. at initial start of chargers			
13	Standby Power	RMS	30W	←	30W	←
14	Charging Power	RMS	1,500W Max.	1,448W Max.	1,500W Max.	1,448W Max.
15	Efficiency/PF		Efficiency 87% , Power Factor 98%		Efficiency 91% , Power Factor 98%	
16	Protection Features		Short circuit protection / over current protection / over voltage protection / reverse connection prevention / pre-charging / *BMS/PCM unblocking feature * BMS/PCM : Battery Management System / Protection Circuit Module			
17	Temperature		Operation : -20℃ ~ +40℃ / Storage : -20℃ ~ +65℃			
18	Size / Weight		W 180mm x H 86mm x L 410mm , 5.5Kg			

* Please refer to the separate manual on the website for the communication protocol related to the communication port mounting type.

3. Common Specifications for all models

Charge current Adjustment Function

Refer to [Product Drawings section](#).

Turning the current adjustment volume to the left decreases the charge current, and turning it to the right increases it. (Multilevel adjustment type).

During charging, you can adjust the current by turning the volume and it will be reflected a few seconds later. The volume is initially set to the maximum right of the volume and can be reduced.

The charge current adjustment volume can be reduced to 60% of the rated charge current.

Bidirectional Communicating Function (COM) – Option

COM (option) – RS232C communication support (Recommended for automation power supply)

〈 charger → upper stage controller 〉 contents of transmission : Charger operating status, etc.

〈 upper stage controller → charger 〉 contents of transmission : Charge start, Charge end, etc.

* Please refer to the attached document for detailed communication protocol specifications. ([Download from Tabos website](#))

Charger and Lithium Battery Charging Characteristics

Data of products manufactured by Tabos.

◇ Charging time calculation

= Amphere hour of Li-Ion Battery (Ah) / Charge current (A) x Correction factor(1.1)

= 104Ah / 45A * 1.1 = 2.5 hour

◇ Elapsed time from initial charge to normal charge / 1500W Charger

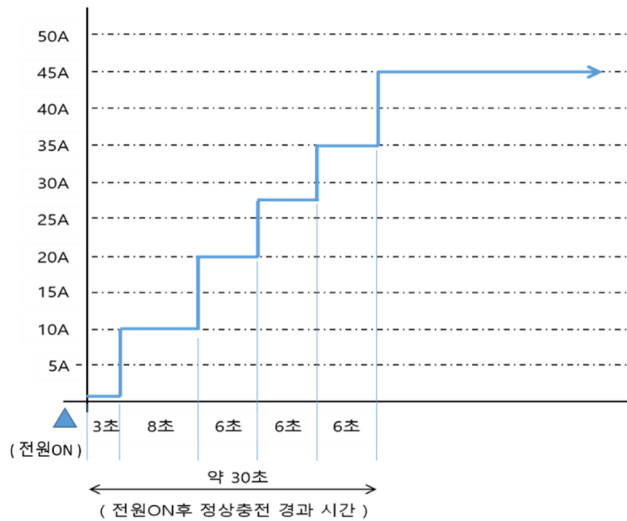

This chart can be implied to 700W charger as well.
Elapsed time could be slightly changed according to circumstances.

Characteristics of electric circuit

◇ LLC Resonant converter type

Soft Switching [ZVS(Zero Voltage Switching) and ZCS(Zero Current Switching)] is possible.
Minimized current noise, controlled heat, increased durability.

◇ Mi-com mounted

Optimum charging performance.
Increased safety and stability.

Procedures of Charge

◇ When the battery is not connected, no electricity is output from the output terminal.

◇ Pre-Charging Function

After the battery is connected, the charger detects the battery voltage and starts charge with the low current when the voltage is lower than normal. (The signal LED lamp flickers alternately between red and green until voltage back to be normal.) This function is implemented only when voltage of the battery is abnormally low. This is to protect the battery and ensure safety.

◇ Soft Start function

If voltage of the battery connected to the charger is within the normal range, it starts to charge by gradually increasing the current in several steps. This is particularly useful when charging batteries mounted on Automatic Guided Vehicle(AGV). When an AGV arrives at home position and is connected to the charger, it can be charged reliably without electrical sparks.

◇ Constant Current Charge

The battery is charged with constant current (CC) until full charge.
For example, the TC-1500W-25V45A / Max29V will continue charging at about 45A.

◇ Constant Voltage Charge

When the battery reaches the full charge voltage, it is charged in the constant voltage (CV) mode. After the battery charged with maximum current that does not exceed full charge voltage, the charge current is gradually decreased. When the charge current is gradually reduced to 10 ~ 20% of the rated charge current (varies by model), it is recognized as a full charge and the charging is stopped. At this time, all operations of charger and fan stops.

Other Specification for Safety and Convenience

◇ Short-Circuit Protection and Automatic Return

The output line automatically detects the short-circuit and cuts off the output. When the problem is solved, it returns.

◇ Under/Over Voltage Protection.

The primary AC power stage and the secondary output DC power stage are electrically isolated.

◇ Reversed Polarity Detecting Device,

The battery and charger will not fail even if the + / - is changed and connected. In this situation, The orange lamp of the signal LED flickers until the user corrects the wiring.

◇ Monitoring display:

Indication of charge voltage and charge current
Inform of the abnormality.

◇ Charge current adjustment : Current adjustment function through volume knob.

4. Model Number / Order Code / Option Marking

① ② ③ ④ ⑤

TC- 700W – 25V 25A / Max29V / COM

TC-1500W – 25V 45A / Max29V / COM

TC-1500W – 25V 45A / Max28V

①	Series name	TC-700W , TC-1500W
②	Battery nominal voltage	25V : for 7 series battery (nominal 25.2V / 29.4V charge max.) 50V : for 14 series battery (nominal 50.4V / 58.8V charge max.)
③	Charge Current Rating	Classification of Charge Current amount
④	Maximum charge voltage	Customers' selection
⑤	Communication port (option)	COM : Bidirectional Communication (RS232C) Charge start command, charge end command, charge current control command, and monitoring information. * D-Sub 9-pin (Male / Male) connector next to output terminal block

5. Selecting Connector Options

<p>SB50A-Gray-M4-800L (for 700W)</p> <p>SB50A-Gray-M6-800L (for 1500W)</p>	<p>1) 50Ah, Terminal for M4 and M6, wire length 800mm,</p> <p>2) Connector : Compatible with Anderson SB50A grey These connectors are connected to each other with the same connector pair without male and female, and they must be inserted only in the direction in which the +/- are matched.</p> <p>3) Output wire combination example * 2 Purchases example: 1 battery, 1 charger * 3 Purchases example: 1 battery, 1 charger, 1 load side * Note: 700W charger terminal is M4, 1500W charger is M6, Tabos batteries are typically M6.</p>	
--	---	---

6. Product Drawings

700W (All models are common)

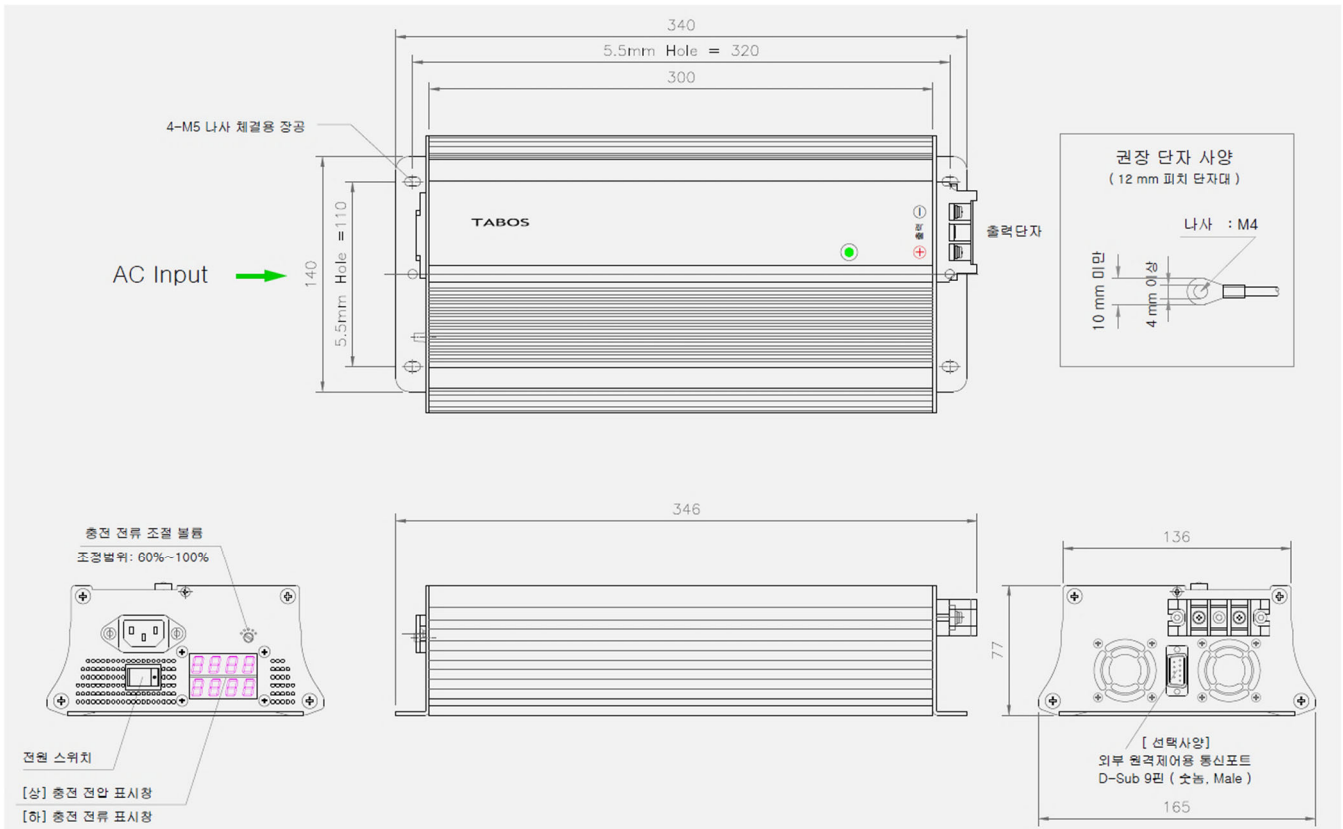

1500W (All models are common)

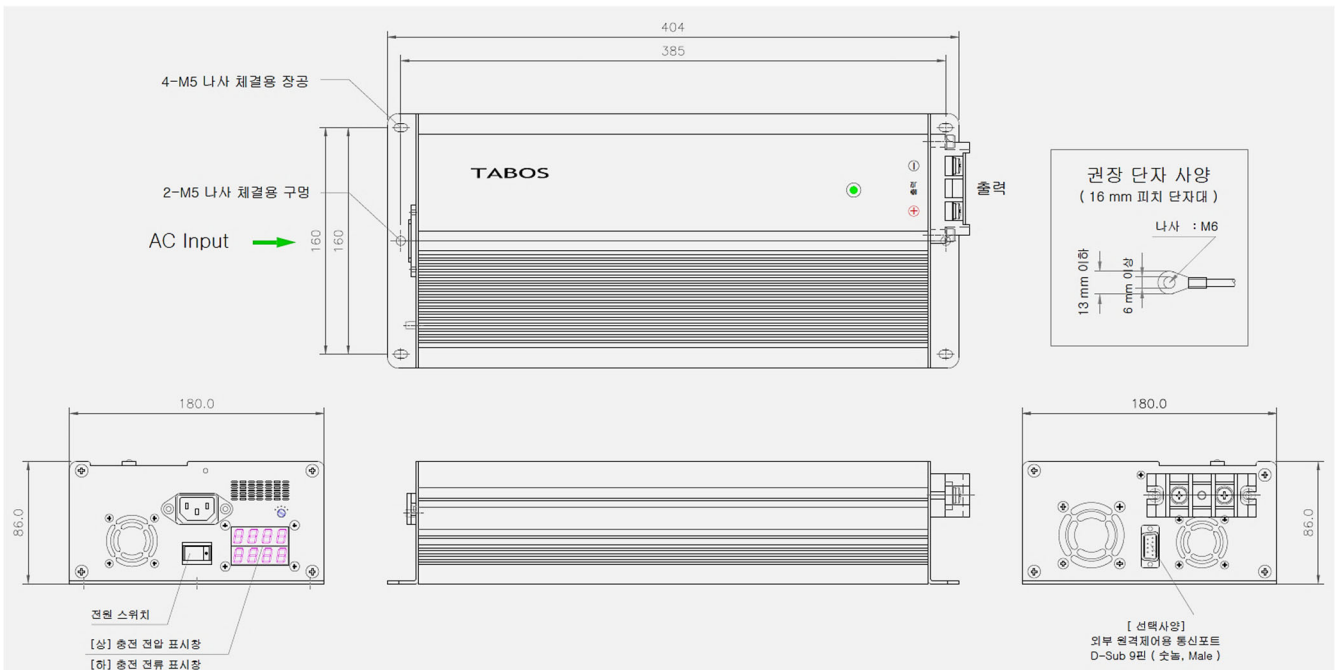

*You can download CAD drawings from our website.